

To accessories. This will be different depending on your year and model. For instance, on a Westfalia camper, you can hook into most accessories at the fat red wire in the bundle behind the driver's seat. On non-Westfalia models, you have to choose the items you want to isolate at the fuse block or else wire them directly to the auxiliary battery.

Wiring a relay into a VW Vanagon

This is what you do if you want to camp or run power to something without affecting your ability to use too much power from your main battery and become unable to start the car.

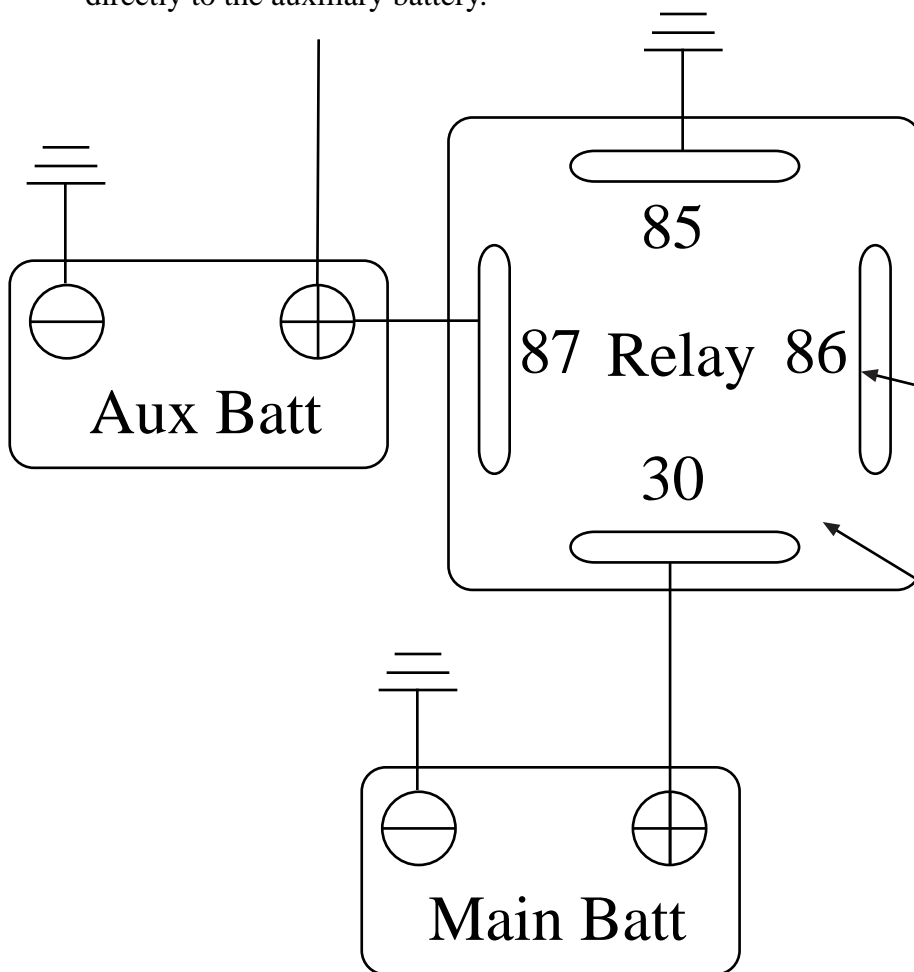

By installing such a relay setup, you are combining the circuits of the two batteries to charge together when the motor is running. When the ignition is turned off, the trigger circuit from the alternator disconnects the two batteries, so one can run appliances without affecting the other.

Blue "trigger" wire from alternator circuit, This is the small blue wire that comes off the back of the alternator.

You'll need a Hella relay (suggested, others will no doubt work) available from many vendors.

This diagram shows the four terminals on the relay, how they are numbered, and where they connect.

Isolating accessories. Most people seem to have more trouble figuring out how to hook all their accessories to the accessory batter than in hooking up the relay. Here is how it can be done on certain Vanagon models:

On 1983 diesels and probably gas Vanagons of that era as well, run a wire from the auxiliary batter positive terminal to a splice in the wire that runs under the dash between the sue box and the front cigarette lighter outlet. Run the wire back under the driver side carpet, behind the appliance cabinets (in a camper) and back to the auxiliary battery in the engine compartment. Your auxiliary battery may be located elsewhere. In a diesel, a good place to put it is next to the main battery. Remove fuse #7 from the panel. Leave a description of what you've done on a piece of paper in the fuse panel. On the wire that you run back to the auxiliary battery, install a 30 Amp fuse somewhere accessible. I chose to put it where the wire ran through the under-sink pantry.

On 1986 and newer Vanagons, remove fuse #3 and leave it out. Put a spade connector on the bottom fuse clip on the #3 fuse slot. Put a fuse inline somewhere you can see it and change it if needed.

Have info on any other year Vanagon? Email me at felder@knology.net.